

Loci and Argand Diagrams

Worked Solutions

1 (a) A locus C_1 is defined by $C_1 = \{z : |z+i| \leq |z-2|\}$.

(i) Indicate by shading on the Argand diagram in the Printed Answer Booklet the region representing C_1 . [2]

(ii) Find the cartesian equation of the boundary line of the region representing C_1 , giving your answer in the form $ax+by+c=0$. [2]

(b) A locus C_2 is defined by $C_2 = \{z : |z+1| \leq 3\} \cap \{z : |z-2i| \geq 2\}$.

Indicate by shading on the Argand diagram in the Printed Answer Booklet the region representing C_2 . [3]

i) perpendicular bisector between $(0,1)$ and $(2,0)$

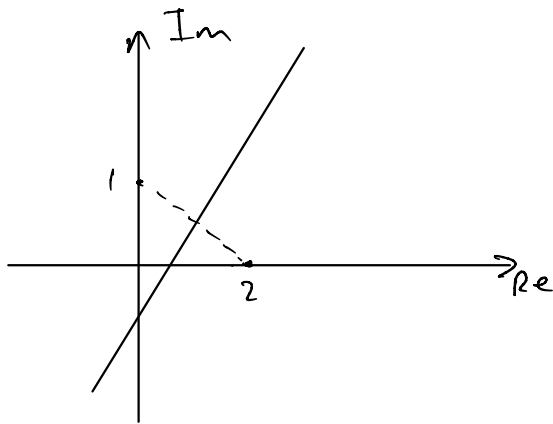

ii) $A=(0,1)$ $B=(2,0)$

$$M=(1, 1/2) \quad m_{AB} = -1/2 \quad \Rightarrow m_{\perp} = 2$$

$$y = 2x + c$$

$$1/2 = 2(1) + c \quad \Rightarrow c = -3/2$$

so, $y = 2x - 3/2$

$$4x - 2y - 3 = 0$$

$$\text{iii) } |z+1| \leq 3$$

Circle, centre $(-1, 0)$, radius 3

$$|z-2i| \geq 2$$

Circle, centre $(0, 2)$, radius 2

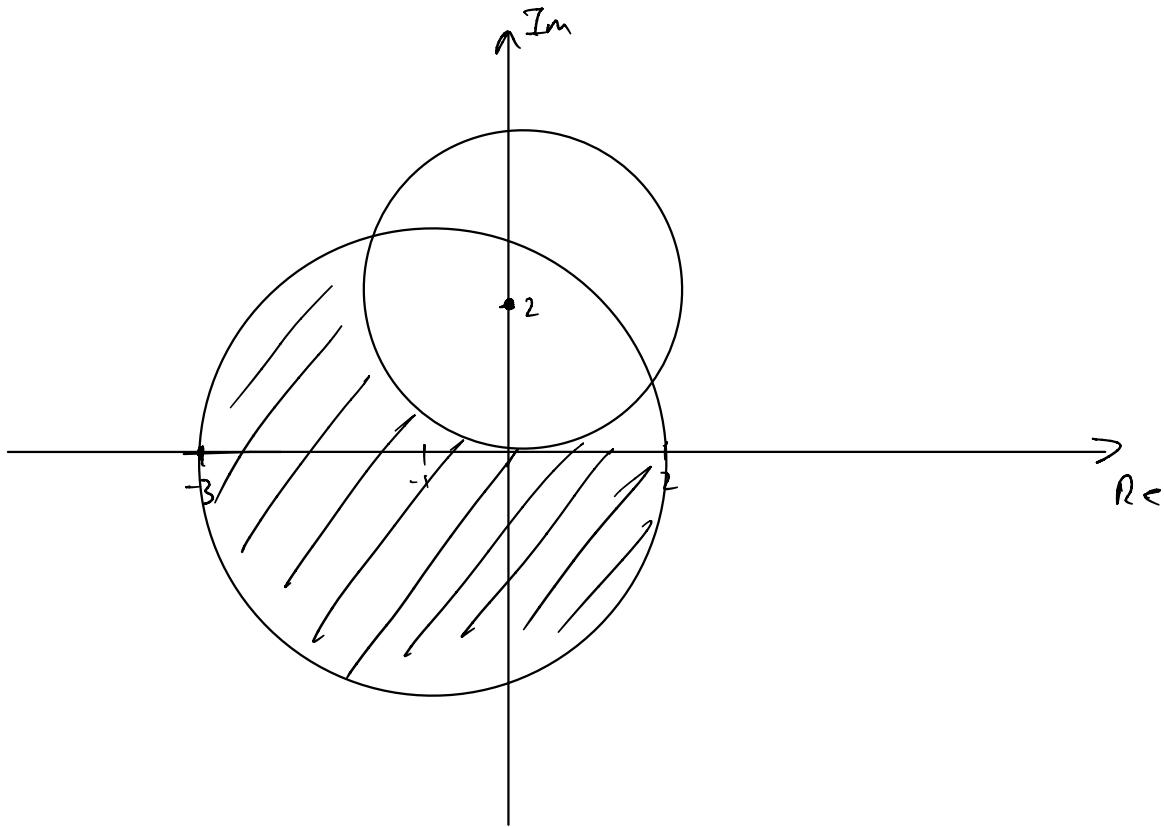

2 Draw the region of the Argand diagram for which $|z-3-4i| \leq 5$ and $|z| \leq |z-2|$.

[4]

$$|z-3-4i| \leq 5$$

circle
centre = $(3, 4)$
radius = 5

$$|z| \leq |z-2|$$

perpendicular bisector
between points $(0, 0), (2, 0)$

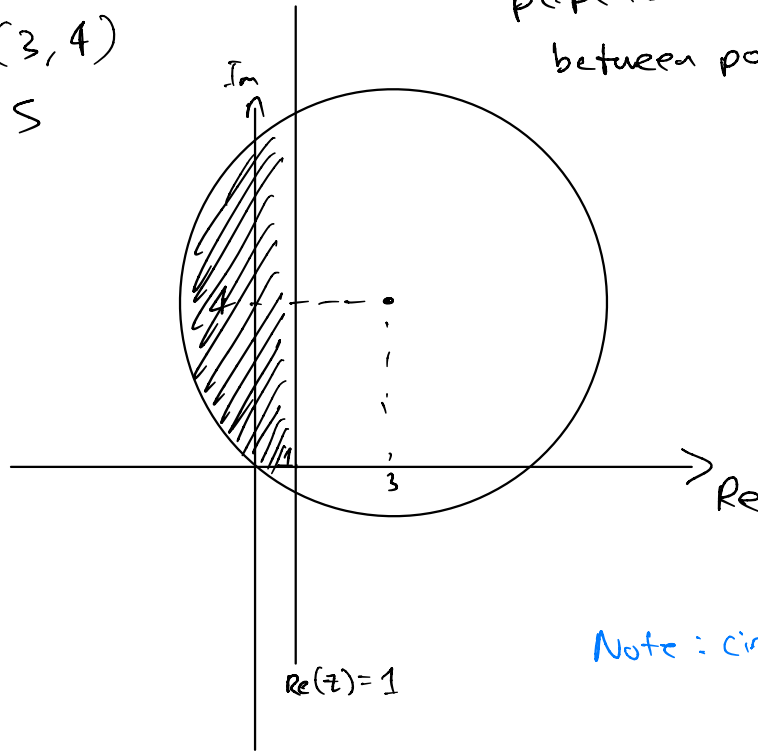

Note: circle goes through origin

3 (a) Sketch on a single Argand diagram the loci given by

(i) $|z - 1 + 2i| = 3$, [2]

(ii) $|z + 1| = |z - 2|$. [2]

(b) Indicate, by shading, the region of the Argand diagram for which $|z - 1 + 2i| \leq 3$ and $|z + 1| \leq |z - 2|$. [2]

a) & b) $|z - 1 + 2i| = 3$

Circle, centre $(1, -2)$, radius 3

$|z + 1| = |z - 2|$

perpendicular bisector between $(-1, 0)$ and $(2, 0)$

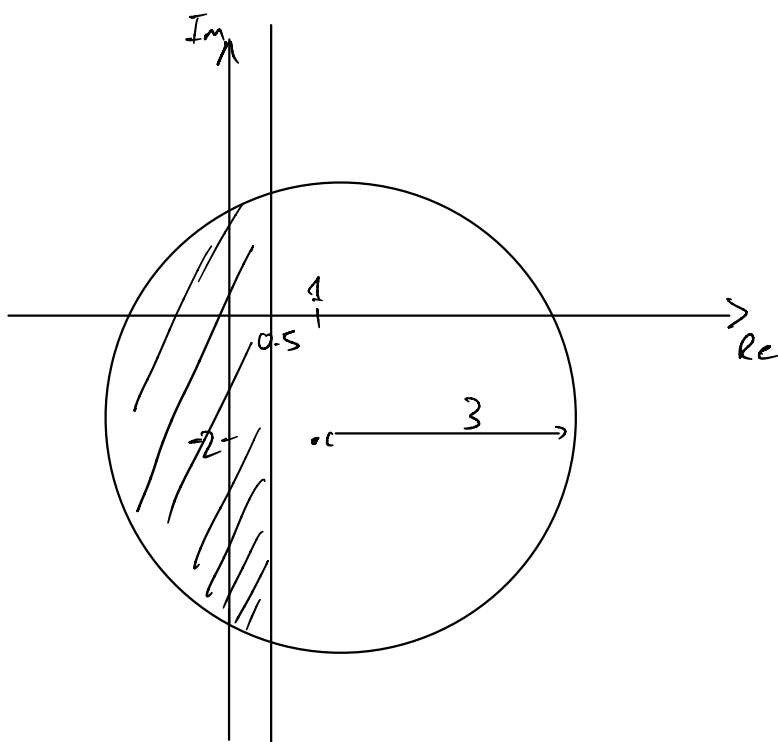

4 Indicate by shading on an Argand diagram the region

$$\{z:|z|\leq|z-4|\} \cap \{z:|z-3-2i|\leq 2\}.$$

[3]

$$|z| \leq |z-4|$$

perpendicular bisector between points $(0,0)$ and $(4,0)$

$$|z-3-2i| \leq 2$$

Circle, with centre $(3,2)$, radius 2

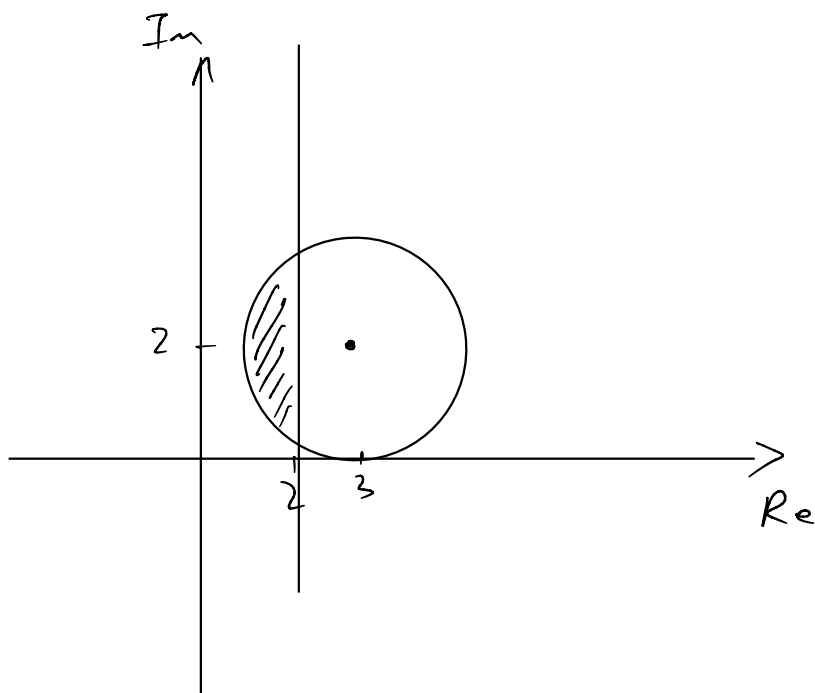

5 Draw the region in an Argand diagram for which $|z| \leq 2$ and $|z| > |z - 3i|$.

[3]

$$|z| \leq 2 :$$

Circle with centre $(0,0)$, radius 2.

$$|z| > |z - 3i|$$

perpendicular bisector between $(0,0)$, $(0,3)$

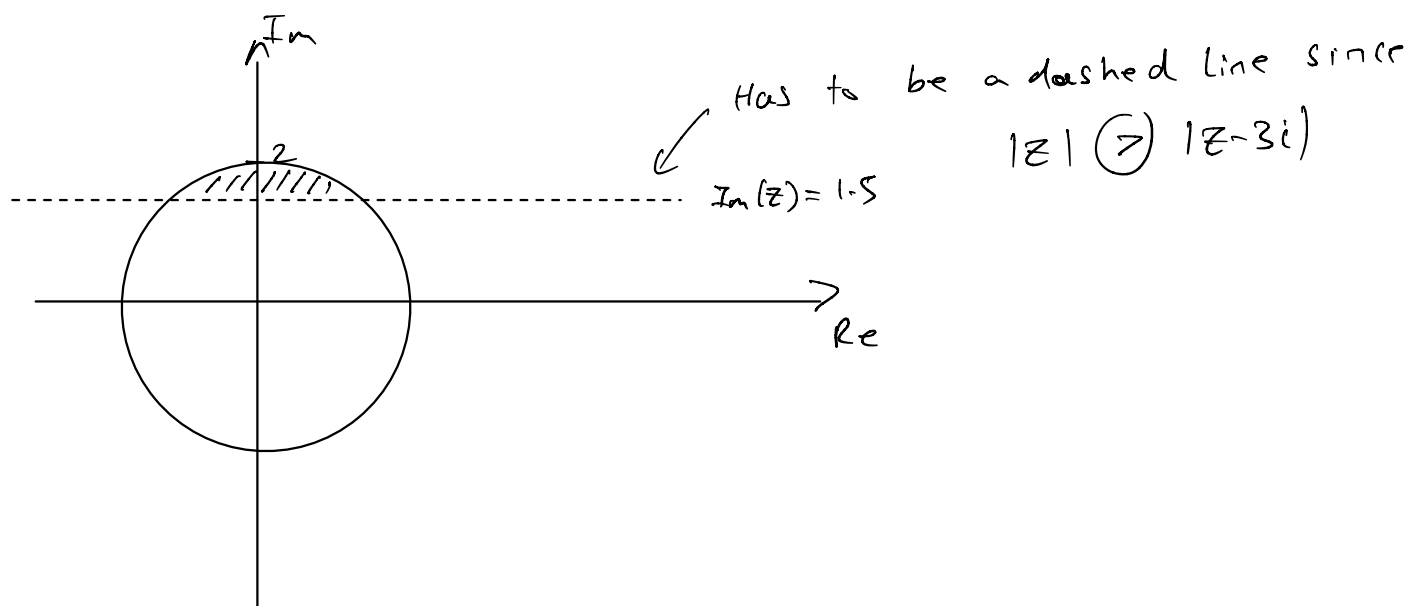

6 Fig. 2 shows two complex numbers z_1 and z_2 represented on an Argand diagram.

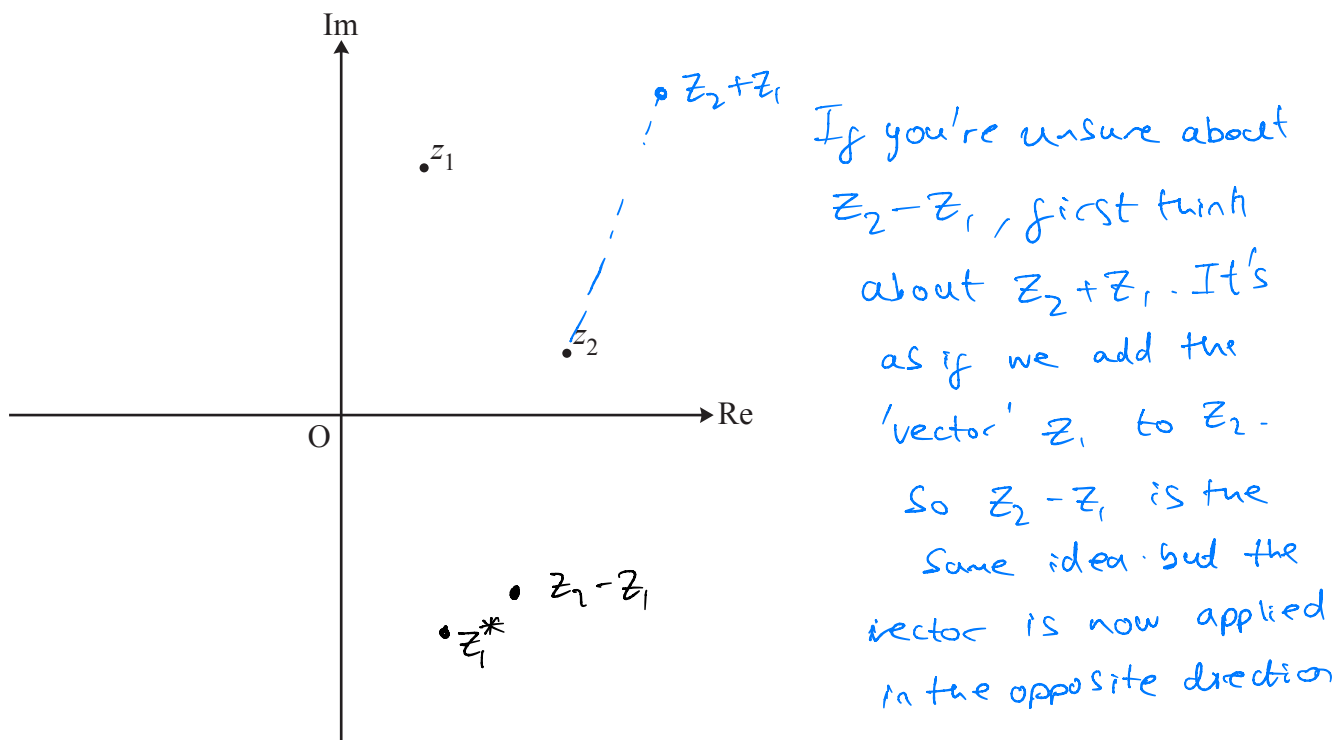

Fig. 2

(a) On the copy of Fig. 2 in the Printed Answer Booklet, mark points representing each of the following complex numbers.

- z_1^*

- $z_2 - z_1$

[2]

(b) In this question you must show detailed reasoning.

In the case where $z_1 = 1 + 2i$ and $z_2 = 3 + i$, find $\frac{z_2 - z_1}{z_1^*}$ in the form $a + ib$, where a and b are real numbers. [2]

$$\begin{aligned}
 \text{b) } \frac{z_2 - z_1}{z_1^*} &= \frac{3 + i - (1 + 2i)}{1 - 2i} = \frac{2 - i}{1 - 2i} \times \frac{1 + 2i}{1 + 2i} \\
 &= \frac{2 - i + 4i + 2}{1 + 4} \\
 &= \frac{4 + 3i}{5} \\
 &= \boxed{\frac{4}{5} + \frac{3}{5}i}
 \end{aligned}$$

- 7 (i) Write down, in complex form, the equation of the locus represented by the circle in the Argand diagram shown in Fig. 3. [2]

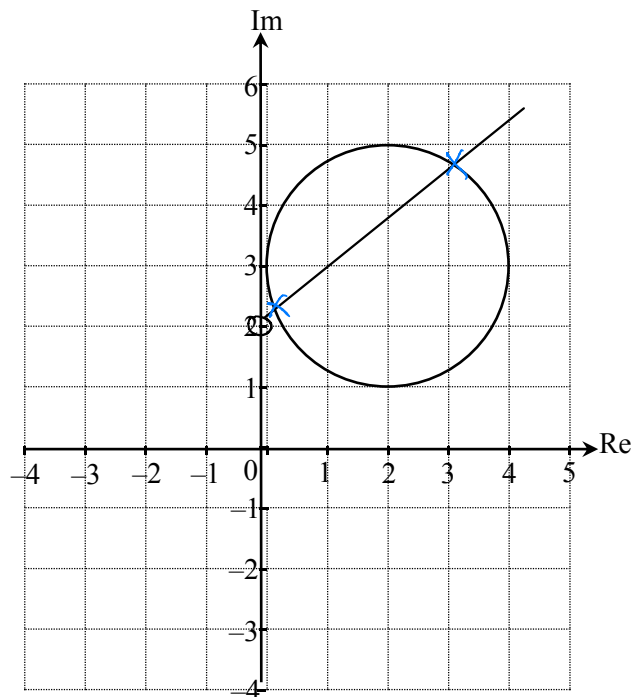

Fig. 3

- (ii) On the copy of Fig. 3 in the Printed Answer Booklet mark with a cross any point(s) on the circle for which $\arg(z - 2i) = \frac{\pi}{4}$. [2]

i) radius = 2
 Centre = (2, 3)

$$\therefore |z - 2 - 3i| = 2$$

ii) see above.

$$\arg(z - 2i) = \frac{\pi}{4}$$

half line, gradient = $\tan\left(\frac{\pi}{4}\right) = 1$

Starting point (0, 2)

8 On separate Argand diagrams, sketch the set of points represented by each of the following.

(a) $|z - 1 - 2i| \leq 4$. [3]

(b) $\arg(z + i) = \frac{1}{3}\pi$. [3]

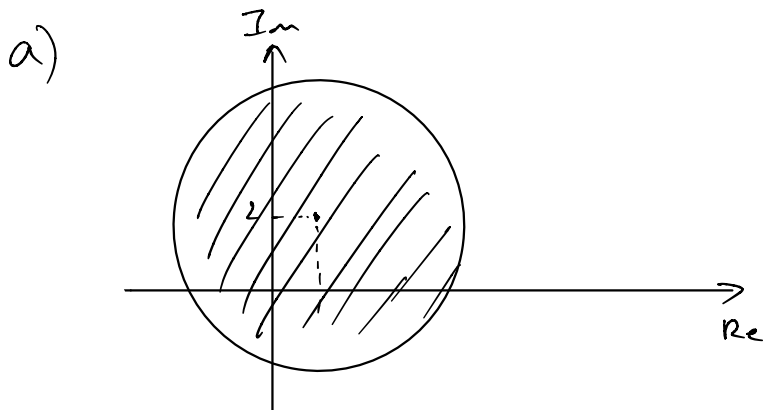

Centre = $(1, 2)$
radius = 4

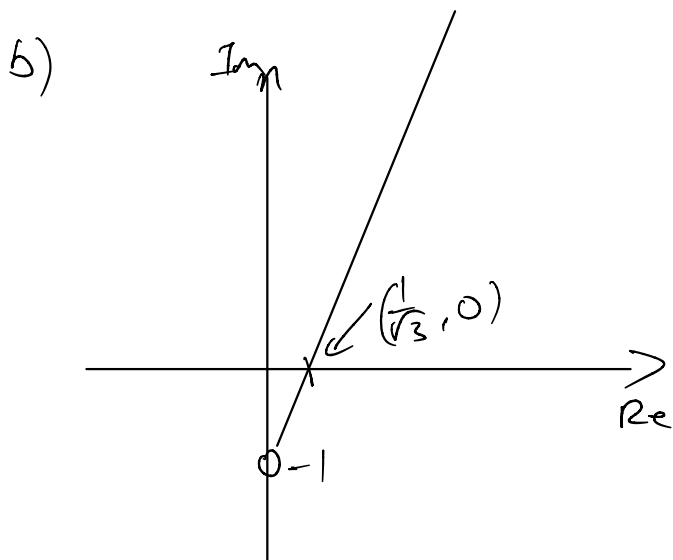

half line.
starting point = $(0, -1)$
gradient = $\tan(\frac{1}{3}\pi) = \sqrt{3}$

9 The Argand diagram below shows the points representing 1 and z , where $|z| = 2$.

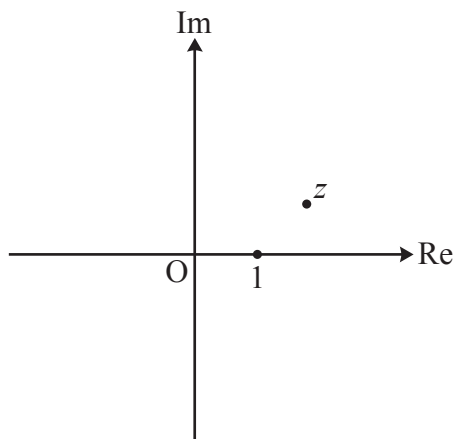

Mark the points representing the following complex numbers on the copy of the diagram in the Printed Answer Booklet, labelling them clearly.

- z^*
- $\frac{1}{z}$
- $1 + z$
- iz

[4]

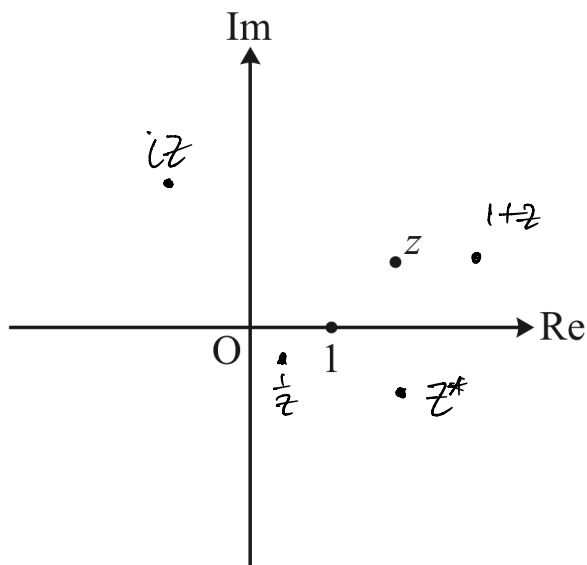

z^* : reflection in Real axis

$\frac{1}{z}$: $|\frac{1}{z}| = \frac{1}{|z|} = \frac{1}{2}$ so closer to origin

$\arg(\frac{1}{z}) = \arg(1) - \arg(z)$
 $= 0 - \arg(z) = -\arg(z)$
 So underneath Real axis now.

$1+z$: 1 unit to the right of z

iz rotation of z 90° anticlockwise about O.

Since $\arg(iz) = \arg(i) + \arg(z)$
 $= \frac{\pi}{2} + \arg(z)$

and $|iz| = |i||z|$
 $= 1|z|$
 $= |z|$

10 (a) On a single Argand diagram, sketch the loci defined by

- $\arg(z-2) = \frac{3}{4}\pi$,
- $|z| = |z+2-i|$.

[4]

(b) In this question you must show detailed reasoning.

The point of intersection of the two loci in part (a) represents the complex number w .

Find w , giving your answer in exact form.

[5]

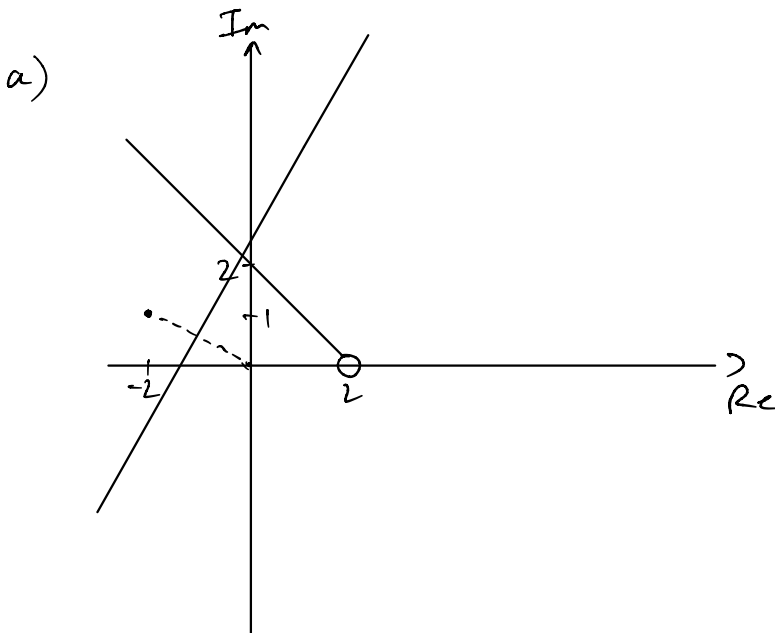

second one is perpendicular bisector between $(0,0)$ and $(-2,1)$.

b) $\arg(z-2) = \frac{3}{4}\pi$

starting point : $(2,0)$

gradient = $\tan(\frac{3}{4}\pi) = -1$

$y = -x + c$

$0 = -2 + c$

$c = 2$

$\Rightarrow y = -x + 2, \quad x < 2$

(A)

$|z| = |z+2-i|$

$|x+yi| = |x+2+(y-1)i|$

$\sqrt{x^2+y^2} = \sqrt{(x+2)^2+(y-1)^2}$

can also use coordinate geometry, if you prefer.

$$x^2 + y^2 = x^2 + 4x + 4 + y^2 - 2y + 1$$

$$2y = 4x + 5$$

$$y = 2x + \frac{5}{2} \quad \textcircled{B}$$

equate \textcircled{A} and \textcircled{B} :

$$-x + 2 = 2x + \frac{5}{2}$$

$$3x = -\frac{1}{2}$$

$$x = -\frac{1}{6}$$

$$\Rightarrow y = \frac{1}{6} + 2 = \frac{13}{6}$$

$$\text{so, } \boxed{w = -\frac{1}{6} + \frac{13}{6}i}$$

- 11 An Argand diagram is shown below. The circle has centre at the point representing $1 + 3i$, and the half line intersects the circle at the origin and at the point representing $4 + 4i$.

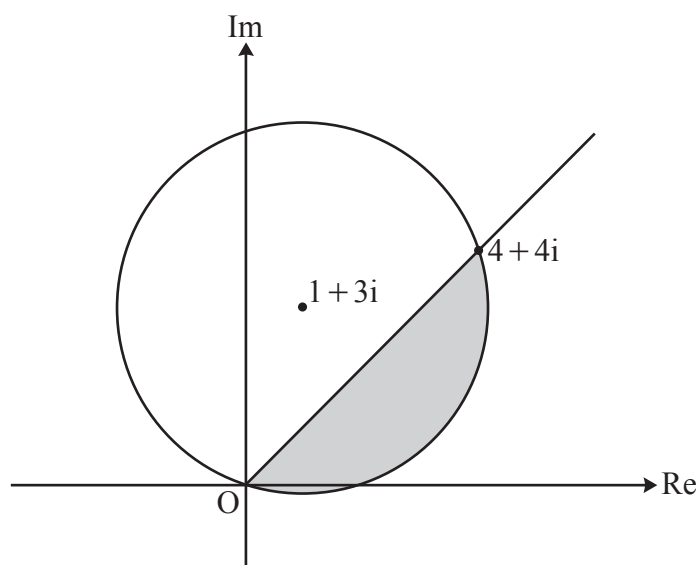

State the **two** conditions that define the set of complex numbers represented by points in the shaded segment, including its boundaries.

[5]

Circle : radius = $|1 + 3i|$ since circle goes through O
 $= \sqrt{1^2 + 3^2}$
 $= \sqrt{10}$

$\therefore |z - 1 - 3i| \leq \sqrt{10}$ since we want region inside circle.

half line: argument = $\tan^{-1}(1/1) = \pi/4$

$\arg(z) = \pi/4$ is eqⁿ of half line.

so $-\pi/2 \leq \arg(z) \leq \pi/4$

Since if we restrict it to $0 \leq \arg(z) \leq \pi/4$ we won't get the small segment under the real axis

$\therefore \{z : |z - 1 - 3i| \leq \sqrt{10}\} \cap \{z : -\pi/2 \leq \arg(z) \leq \pi/4\}$

(Set notation isn't required.)

12 Fig. 9 shows a sketch of the region OPQ of the Argand diagram defined by

$$\{z : |z| \leq 4\sqrt{2}\} \cap \{z : \frac{1}{4}\pi \leq \arg z \leq \frac{1}{3}\pi\}.$$

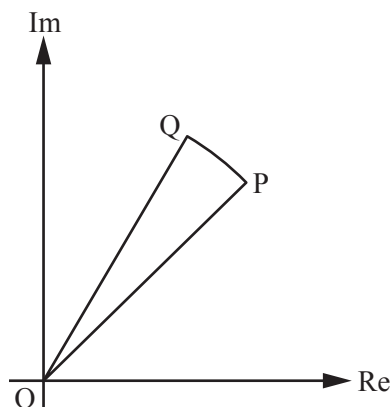

Fig. 9

(i) Find, in modulus-argument form, the complex number represented by the point P. [2]

(ii) Find, in the form $a + ib$, where a and b are exact real numbers, the complex number represented by the point Q. [3]

(iii) In this question you must show detailed reasoning.

Determine whether the points representing the complex numbers

- $3 + 5i$
- $5.5(\cos 0.8 + i \sin 0.8)$

lie within this region.

[4]

i) P is where $\arg(z) = \frac{1}{4}\pi$ and $|z| = 4\sqrt{2}$

i.e. $P = 4\sqrt{2} (\cos(\frac{1}{4}\pi) + i \sin(\frac{1}{4}\pi))$

(ii) Q is where $\arg(z) = \frac{1}{3}\pi$ and $|z| = 4\sqrt{2}$

i.e. $Q = 4\sqrt{2} (\cos(\frac{1}{3}\pi) + i \sin(\frac{1}{3}\pi))$

$$= 4\sqrt{2} (\frac{1}{2} + i \frac{\sqrt{3}}{2})$$

$$= 2\sqrt{2} + 2\sqrt{6}i$$

13 (i) On an Argand diagram draw the locus of points which satisfy $\arg(z-4i) = \frac{\pi}{4}$. [2]

(ii) Give, in complex form, the equation of the circle which has centre at $6+4i$ and touches the locus in part (i). [4]

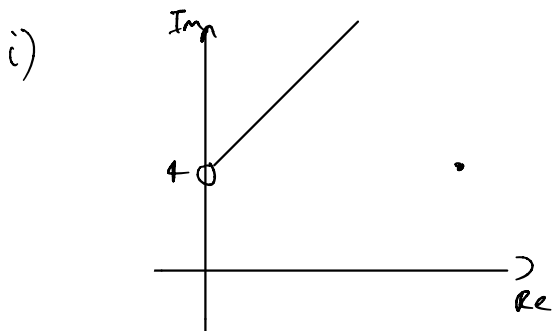

always find starting point -
 $(0, 4)$ in this case.

a) centre $(6, 4)$

$\Rightarrow |z - 6 - 4i| = r$ where r is the radius

If the circle touches the half line we need to find the shortest distance. Since $\arg(z-4i) = \pi/4$, this isn't

that hard as the triangle is isosceles.

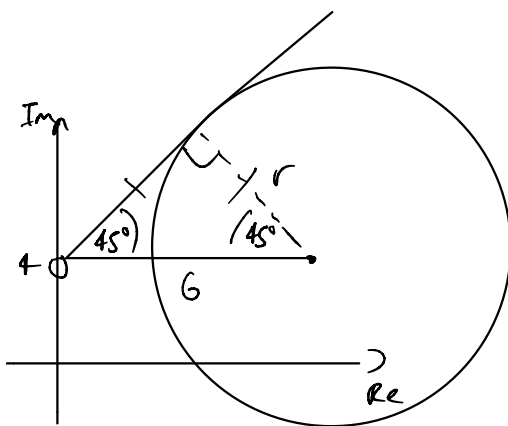

$$\cos(45) = \frac{r}{6}$$

$$\Rightarrow r = 6 \cos(45) = 3\sqrt{2}$$

So $|z - 6 - 4i| = 3\sqrt{2}$

14 Two sets of complex numbers are given by $\{z : \arg(z-10) = \frac{3}{4}\pi\}$ and $\{z : |z-3-6i| = k\}$, where k is a positive constant. In an Argand diagram, one of the points of intersection of the two loci representing these sets lies on the imaginary axis.

(a) Sketch the loci on an Argand diagram. [4]

(b) In this question you must show detailed reasoning.

Find the complex numbers represented by the points of intersection. [7]

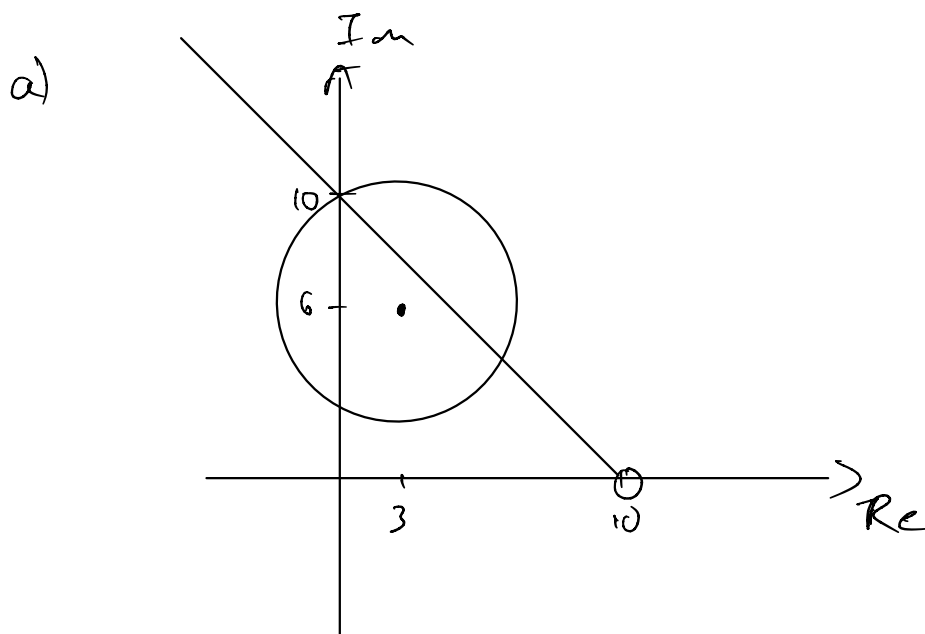

b) $\arg(z-10) = \frac{3}{4}\pi$

starting point (10, 0)

gradient = $\tan(\frac{3}{4}\pi) = -1$

$y = -x + c$

$y = -x + 10$ by inspection

$|z-3-6i| = k$

First find k .

$$k = \sqrt{(3-0)^2 + (6-10)^2}$$

$$= \sqrt{9+16} = 5$$

so $|z-3-6i| = 5$

$$\text{centre} = (3, 6)$$

$$\text{radius} = 5$$

$$\therefore (x-3)^2 + (y-6)^2 = 25$$

To find intersection, sub in $y = -x + 10$ in :

$$(x-3)^2 + (-x+10-6)^2 = 25$$

$$(x-3)^2 + (-x+4)^2 = 25$$

$$x^2 - 6x + 9 + x^2 - 8x + 16 = 25$$

$$2x^2 - 14x = 0$$

$$x^2 - 7x = 0$$

$$x(x-7) = 0$$

$$x = 0 \quad \text{or} \quad x = 7$$

$$\downarrow$$

$$y = 10$$

$$\downarrow$$

$$y = 3$$

So, 10i & 7+3i are the points of intersection

15 The locus C_1 is defined by $C_1 = \{z : 0 \leq \arg(z+i) \leq \frac{1}{4}\pi\}$.

(a) Indicate by shading on the Argand diagram in the Printed Answer Booklet the region representing C_1 . [2]

(b) Determine whether the complex number $1.2 + 0.8i$ is in C_1 . [2]

The locus C_2 is the set of complex numbers represented by the interior of the circle with radius 2 and centre 3. The locus C_2 is illustrated on the Argand diagram below.

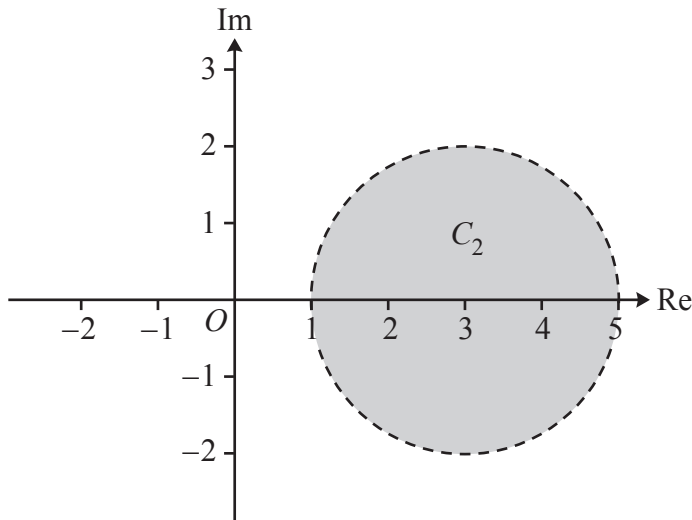

(c) Use set notation to define C_2 . [2]

(d) Determine whether the complex number $1.2 + 0.8i$ is in C_2 . [2]

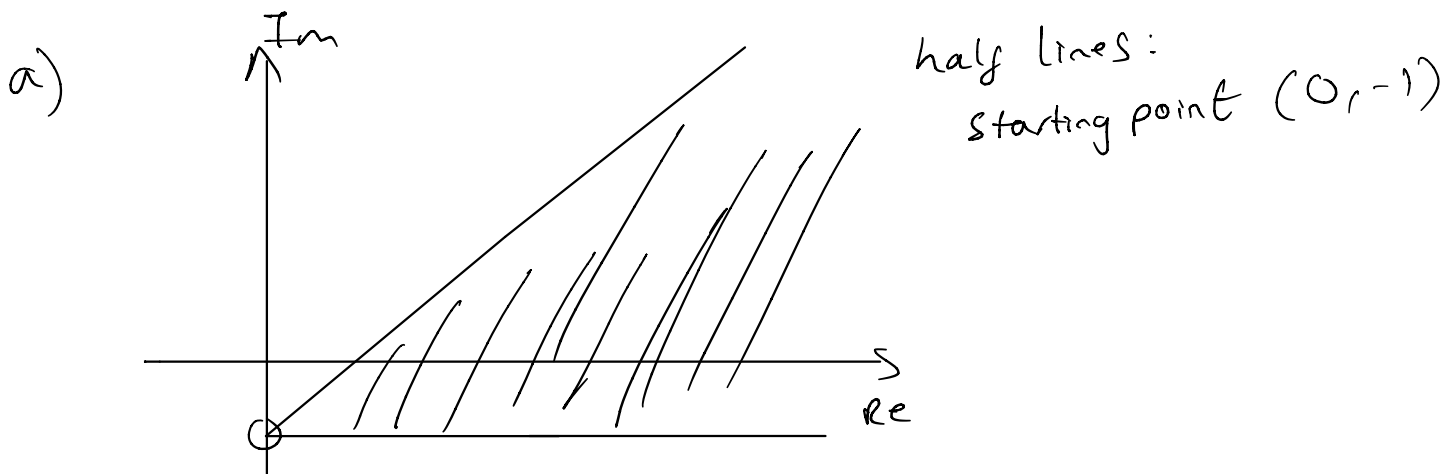

b) substitution:
 $\arg(1.2 + 0.8i + i) = \arg(1.2 + 1.8i) = \tan^{-1}\left(\frac{1.8}{1.2}\right)$
 $= 0.98... > \frac{\pi}{4}$
 so no, it's not in C_1

c) circle
centre (3,0)
radius 2

$$\{z : z \in \mathbb{C}, |z - 3| \leq 2\}$$

d) like part b,

Best way to check is to sub $z = 1.2 + 0.8i$ in :

$$\begin{aligned} |1.2 + 0.8i - 3| &= |-1.8 + 0.8i| \\ &= \sqrt{1.8^2 + 0.8^2} \\ &= \frac{\sqrt{97}}{5} \\ &= 1.969\dots < 2 \end{aligned}$$

So yes, it is in C_2

16 In an Argand diagram, the point P representing the complex number w lies on the locus defined by $\{z: \arg(z-7) = \frac{3}{4}\pi\}$. You are given that $\operatorname{Re}(w) = 1$.

(a) Find w . [2]

The point P also lies on the locus defined by $\{z: |z+3-9i| = k\}$, where k is a constant.

(b) Find the complex number represented by the other point of intersection of the loci defined by $\{z: |z+3-9i| = k\}$ and $\{z: \arg(z-7) = \frac{3}{4}\pi\}$. [7]

a) $\arg(z-7) = \frac{3}{4}\pi$

Starting point: $(7, 0)$

gradient = $\tan(\frac{3}{4}\pi) = -1$

$y = -x + c$

$\Rightarrow 0 = -7 + c$

$c = 7$

so $y = -x + 7$ (B) (for $x < 7$)

Sub (A) into (B): $y = 6 \quad \therefore \boxed{w = 1 + 6i}$

$\operatorname{Re}(w) = 1$

$\Rightarrow x = 1$ (A)

b) $|z+3-9i| = k$

Centre: $(-3, 9)$

radius = $\sqrt{(1-(-3))^2 + (6-9)^2}$

$= \sqrt{25}$

$= 5$

$\Rightarrow k = 5$

Cartesian equation: $(x+3)^2 + (y-9)^2 = 25$ (A)

since P lies on locus

Now, $\arg(z-7) = \frac{3}{4}\pi \Leftrightarrow y = -x + 7 \quad x < 7$ (B)

Sub (B) into (A): $(x+3)^2 + (-x-2)^2 = 25$

$x^2 + 6x + 9 + x^2 + 4x + 4 = 25$

$$2x^2 + 10x - 12 = 0$$

$$x^2 + 5x - 6 = 0$$

$$(x+6)(x-1) = 0$$

$$x = -6 \text{ or } \underbrace{x = 1}_w$$



Sub into $y = -x + 7$:

$$y = 13$$

$$\therefore \boxed{-6 + 13i}$$

17 (a) On separate Argand diagrams, show the set of points representing each of the following inequalities.

(i) $|z| \leq \sqrt{5}$ [3]

(ii) $|z+2-4i| \geq |z-2-6i|$ [3]

(b) Show that there is a unique value of z , which should be determined, for which both $|z| \leq \sqrt{5}$ and $|z+2-4i| \geq |z-2-6i|$. [8]

i) $|z| \leq \sqrt{5}$
 centre = (0, 0)
 radius = $\sqrt{5}$

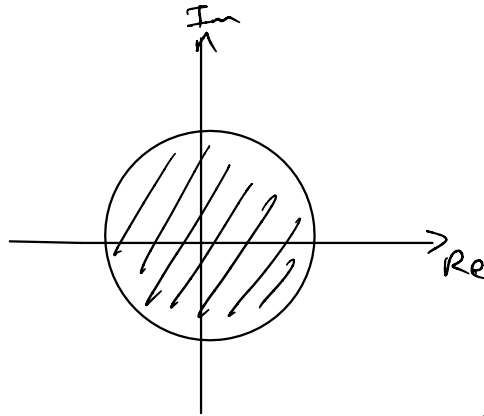

ii) $|z+2-4i| \geq |z-2-6i|$
 centre = (-2, 4) (2, 6)
 This is a perpendicular bisector between these two points.

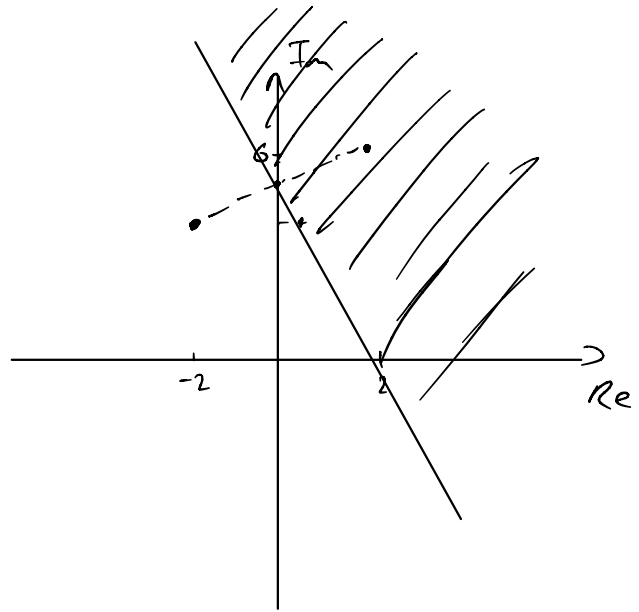

b) $|z| = \sqrt{5}$
 $x^2 + y^2 = 5$

$|z+2-4i| = |z-2-6i|$

Method 1: (perpendicular bisector)

$A = (-2, 4)$, $B = (2, 6)$

$M = (0, 5)$

$m_{AB} = \frac{6-4}{2-(-2)} = \frac{2}{4} = \frac{1}{2}$ $m_{\perp} = -2$

$$\Rightarrow y = -2x + 5$$

$$y = -2x + 5 \quad (c=5 \text{ by inspection})$$

Method 2: Algebra

$$|x+iy + 2-4i| = |x+iy - 2-6i|$$

$$\sqrt{(x+2)^2 + (y-4)^2} = \sqrt{(x-2)^2 + (y-6)^2}$$

$$\cancel{x^2} + 4x + 4 + \cancel{y^2} - 8y + 16 = \cancel{x^2} - 4x + 4 + \cancel{y^2} - 12y + 36$$

$$4y + 20 = -8x + 40$$

$$y + 5 = -2x + 10$$

$$y = -2x + 5$$

To find point(s) of intersection:

$$x^2 + (-2x+5)^2 = 5$$

$$x^2 + 4x^2 - 20x + 25 = 5$$

$$5x^2 - 20x + 20 = 0$$

$$x^2 - 4x + 4 = 0$$

$$(x-2)^2 = 0$$

$$x=2, \Rightarrow y = -2(2) + 5 = 1$$

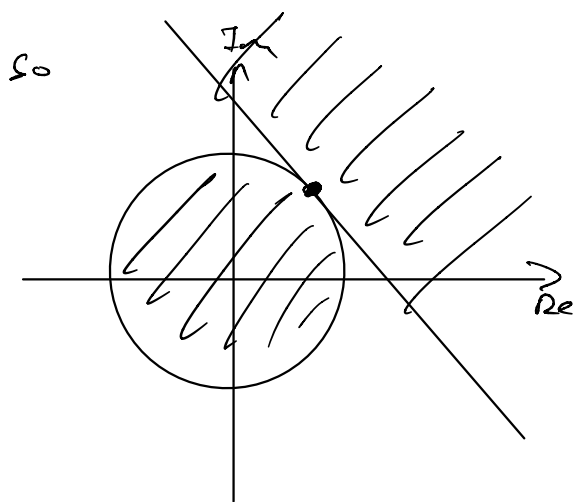

Argand Diagram looks like this.
Only point satisfying both regions is therefore

$$\boxed{2 + i}$$

18 In this question you must show detailed reasoning.

You are given that $f(z) = 4z^4 - 12z^3 + 41z^2 - 128z + 185$ and that $2+i$ is a root of the equation $f(z) = 0$.

(a) Express $f(z)$ as the product of two quadratic factors with integer coefficients. [5]

(b) Solve $f(z) = 0$. [3]

Two loci on an Argand diagram are defined by $C_1 = \{z:|z|=r_1\}$ and $C_2 = \{z:|z|=r_2\}$ where $r_1 > r_2$. You are given that two of the points representing the roots of $f(z) = 0$ are on C_1 and two are on C_2 . R is the region on the Argand diagram between C_1 and C_2 .

(c) Find the exact area of R . [4]

(d) ω is the sum of all the roots of $f(z) = 0$.

Determine whether or not the point on the Argand diagram which represents ω lies in R . [2]

a) let $\alpha = 2+i$, then $\beta = 2-i$

$\alpha + \beta = 4$ $\alpha\beta = 5$

$\therefore (z^2 - 4z + 5)$ is a factor of $f(z)$

$$\begin{array}{r}
 z^2 - 4z + 5 \mid \overline{4z^4 - 12z^3 + 41z^2 - 128z + 185} \\
 \underline{-(4z^4 - 16z^3 + 20z^2)} \quad \downarrow \\
 4z^3 + 21z^2 - 128z \\
 \underline{-(4z^3 - 16z^2 + 20z)} \quad \downarrow \\
 37z^2 - 148z + 185 \\
 \underline{37z^2 - 148z + 185} \\
 0
 \end{array}$$

$\therefore f(z) = (4z^2 + 4z + 37)(z^2 - 4z + 5)$

note: other perfectly acceptable methods exist!

b) In this question you must show detailed reasoning.

if you state all the roots without showing working you won't get all the marks.

$$z = \frac{-4 \pm \sqrt{4^2 - 4(4)(37)}}{2(4)} = \frac{-4 \pm 24i}{8}$$

$$= \boxed{\frac{-1 \pm 6i}{2}}$$

or $z = \boxed{2 \pm i}$

c)

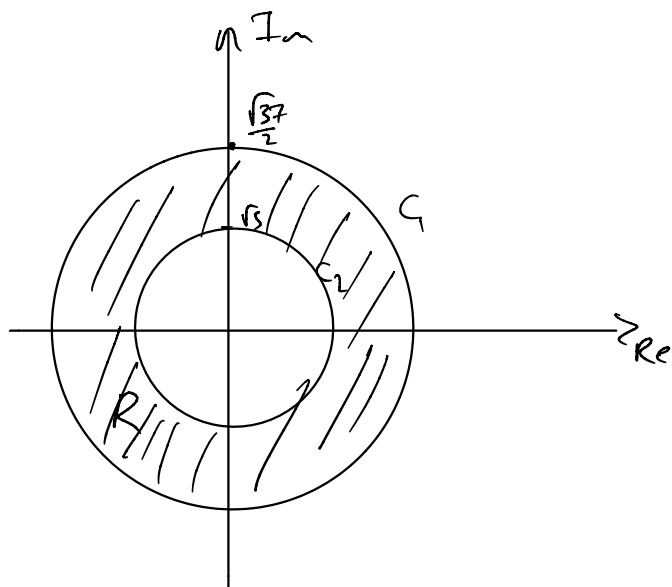

$$\text{for } C_1, r = \sqrt{\left(\frac{-1}{2}\right)^2 + 3^2}$$

$$= \frac{\sqrt{37}}{2}$$

$$\text{for } C_2, r = \sqrt{2^2 + 1^2}$$

$$= \sqrt{5}$$

$$\text{Area of } R = \text{Area of } C_1 - \text{Area of } C_2$$

$$= \pi \left(\frac{\sqrt{37}}{2}\right)^2 - \pi (\sqrt{5})^2 = \frac{17}{4} \pi$$

d) $w = \frac{-b}{a} = \frac{12}{4} = 3$

$$\text{or } w = 2 + i + 2 - i + \frac{-1 + 6i}{2} + \frac{-1 - 6i}{2}$$

$$= 3$$

$$\sqrt{5} = 2.23\dots$$

$$\frac{\sqrt{37}}{2} = 3.04\dots$$

$$\text{so } \sqrt{5} < 3 < \frac{\sqrt{37}}{2}$$

$$\Rightarrow w \text{ is in } R$$

19 In this question you must show detailed reasoning.

Two loci, C_1 and C_2 , are defined as follows.

$$C_1 = \left\{ z : \arg(z+2-i) = \frac{1}{4}\pi \right\} \text{ and } C_2 = \left\{ z : \arg(z-2-\sqrt{3}-2i) = \frac{2}{3}\pi \right\}$$

By considering the representations of C_1 and C_2 on an Argand diagram, determine the locus $C_1 \cap C_2$.

[7]

C_1 : half line

starting point = $(-2, 1)$

gradient = $\tan\left(\frac{1}{4}\pi\right) = 1$

$\therefore y = x + c$

$1 = -2 + c \Rightarrow c = 3$

so $y = x + 3$, $x > -2$

C_2 : half line.

starting point $(2 + \sqrt{3}, 2)$

gradient = $\tan\left(\frac{2}{3}\pi\right) = -\sqrt{3}$

$y = -\sqrt{3}x + c$

$2 = -\sqrt{3}(2 + \sqrt{3}) + c$

$2 = -2\sqrt{3} - 3 + c$

$c = 5 + 2\sqrt{3}$

$y = -\sqrt{3}x + 5 + 2\sqrt{3}$, $x < 2 + \sqrt{3}$

Intersection:

$x + 3 = -\sqrt{3}x + 5 + 2\sqrt{3}$

$x(1 + \sqrt{3}) = 2 + 2\sqrt{3}$

$x = \frac{2 + 2\sqrt{3}}{1 + \sqrt{3}} = \frac{2(1 + \sqrt{3})}{1 + \sqrt{3}} = 2 \Rightarrow y = 5$

so $C_1 \cap C_2 = 2 + 5i$

If you're not sure about this, sketch the argand diagram

Note this is necessary to get full marks as it proves that $2 + 5i$ is valid as $-2 < 2 < 2 + \sqrt{3}$.

- 20 The Argand diagram shows a circle of radius 3. The centre of the circle is the point which represents the complex number $4 - 2i$.

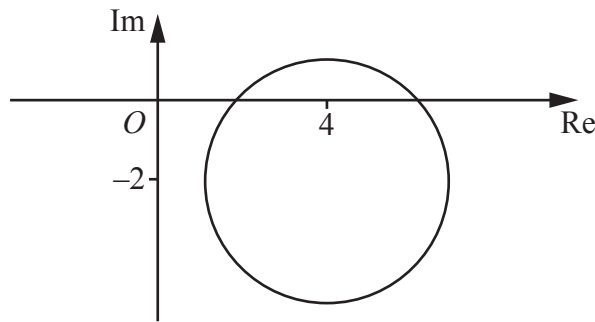

- (a) Use set notation to define the locus of complex numbers, z , represented by points which lie on the circle. [2]

The locus L is defined by $L = \{z : z \in \mathbb{C}, |z - i| = |z + 2|\}$.

- (b) On the Argand diagram in the Printed Answer Booklet, sketch and label the locus L . [2]

You are given that the locus $\{z : z \in \mathbb{C}, \arg(z - 1) = \frac{1}{4}\pi, \operatorname{Re}(z) = 3\}$ contains only one number.

- (c) Find this number. [2]

a) $\{z : |z - 4 + 2i| = 3, z \in \mathbb{C}\}$

b) perpendicular bisector, between $(0, 1)$ and $(-2, 0)$

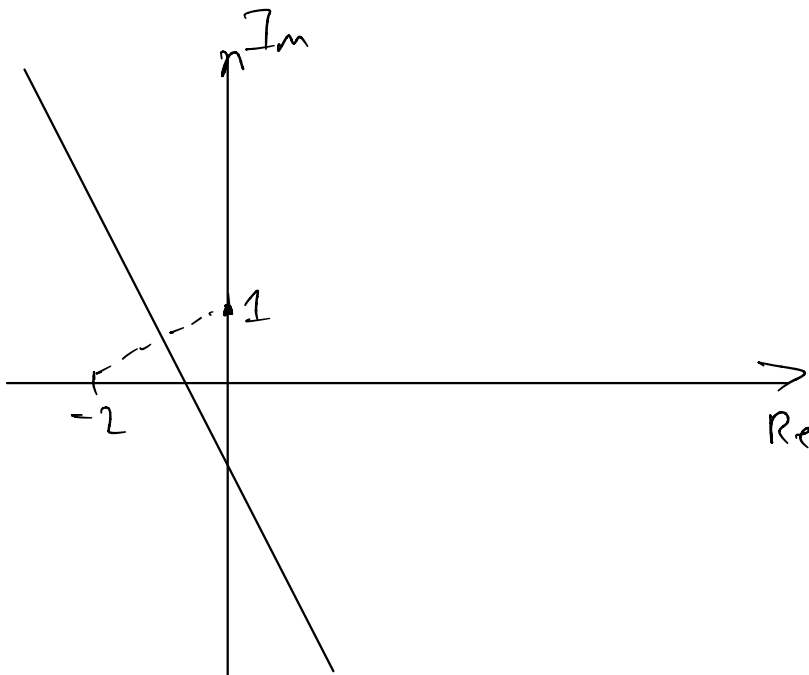

c) Method 1:

$$\arg(z-1) = \frac{1}{4}\pi$$

$$\arg(x+iy-1) = \frac{1}{4}\pi$$

$$\arg(3+iy-1) = \frac{1}{4}\pi$$

$$\arg(iy+2) = \frac{1}{4}\pi$$

$$\tan^{-1}\left(\frac{y}{2}\right) = \frac{1}{4}\pi$$

$$\frac{y}{2} = \tan\left(\frac{1}{4}\pi\right) = 1 \quad y = 2 \quad \therefore$$

$3+2i$ is only number
in set

Method 2:

half line

starting point: $(1, 0)$

$$\text{gradient} = \tan\left(\frac{\pi}{4}\right) = 1$$

$$y = x + c$$

$$0 = 1 + c$$

$$\Rightarrow c = -1$$

$$\text{so } y = x - 1$$

$$\operatorname{Re}(z) = 3 \quad \text{so } x = 3$$

$$\Rightarrow y = 3 - 1 = 2$$

$3+2i$ is only number
in set

As nice as this method looks,
in my opinion method 2 is
better and can lead to
less errors with signs
when the argument
isn't between 0 and $\frac{\pi}{2}$.

21 In this question you must show detailed reasoning.

- (a) Find the roots of the equation $2z^2 - 2z + 5 = 0$. [2]

The loci C_1 and C_2 are given by $|z| = |z - 2i|$ and $|z - 2| = \sqrt{5}$ respectively.

- (b) (i) Sketch on a single Argand diagram the loci C_1 and C_2 , showing any intercepts with the imaginary axis. [3]

- (ii) Indicate, by shading on your Argand diagram, the region

$$\{z: |z| \leq |z - 2i|\} \cap \{z: |z - 2| \leq \sqrt{5}\}. \quad [1]$$

- (c) (i) Show that both of the roots of the equation $2z^2 - 2z + 5 = 0$ satisfy $|z - 2| < \sqrt{5}$. [2]

- (ii) State, with a reason, which root of the equation $2z^2 - 2z + 5 = 0$ satisfies $|z| < |z - 2i|$. [1]

- (d) On the same Argand diagram as part (b), indicate the positions of the roots of the equation $2z^2 - 2z + 5 = 0$. [2]

$$a) \quad z = \frac{2 \pm \sqrt{(-2)^2 - 4(2)(5)}}{2(2)} = \frac{2 \pm \sqrt{-36}}{4} = \frac{2 \pm 6i}{4} = \frac{1 \pm 3i}{2}$$

b) $|z| = |z - 2i|$
 perpendicular bisector between $(0,0)$ and $(0,2)$

$|z - 2| \leq \sqrt{5}$
 circle, centre $(2,0)$, radius $\sqrt{5}$

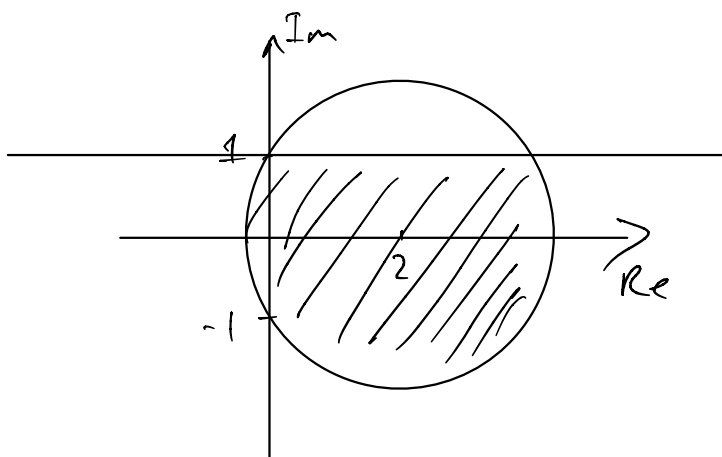

$$(x-2)^2 + y^2 = 5$$

$$(0-2)^2 + y^2 = 5$$

$$y^2 = 1$$

$$y = \pm 1$$

$$\begin{aligned}
 \text{d) } |z-2| &= \left| \frac{1}{2} \pm \frac{3}{2}i - 2 \right| = \left| -\frac{3}{2} \pm \frac{3}{2}i \right| \\
 &= \sqrt{\left(-\frac{3}{2}\right)^2 + \left(\pm\frac{3}{2}\right)^2} \\
 &= \sqrt{\frac{9}{4} + \frac{9}{4}} \\
 &= \sqrt{\frac{18}{4}} \\
 &= \sqrt{\frac{9}{2}} \\
 &< \sqrt{\frac{10}{2}} = \sqrt{5} \quad \square
 \end{aligned}$$

$$\begin{aligned}
 \text{ii) } \frac{1}{2} - \frac{3}{2}i & \quad \text{because we need } \operatorname{Im}(z) < 1 \\
 & \text{and } \operatorname{Im}\left(\frac{1}{2} - \frac{3}{2}i\right) = -\frac{3}{2} < 1
 \end{aligned}$$

d)

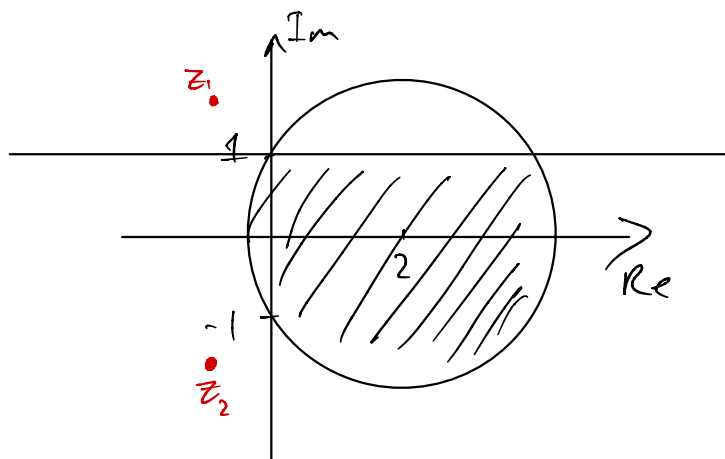

$$\text{let } z_1 = -\frac{1}{2} + \frac{3}{2}i$$

$$z_2 = -\frac{1}{2} - \frac{3}{2}i$$

22 In an Argand diagram the points representing the numbers $2 + 3i$ and $1 - i$ are two adjacent vertices of a square, S .

(a) Find the area of S . [3]

(b) Find all the possible pairs of numbers represented by the other two vertices of S . [4]

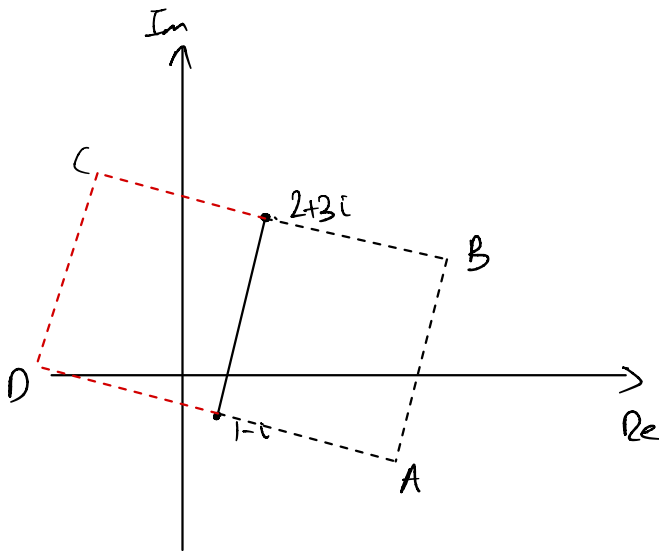

a) since they are adjacent vertices,

$$\text{side length} = \sqrt{(2-1)^2 + (3-(-1))^2} = \sqrt{17}$$

$$\therefore \text{Area of } S = (\sqrt{17})^2 = 17$$

b) I will use a vector method.

let $P = (1, -1)$ and $Q = (2, 3)$

$$\vec{PQ} = \begin{pmatrix} 1 \\ 4 \end{pmatrix} \therefore \vec{QB} = \begin{pmatrix} 4 \\ -1 \end{pmatrix} \text{ and } \vec{QC} = \begin{pmatrix} -4 \\ 1 \end{pmatrix}$$

$$\vec{PA} = \begin{pmatrix} 4 \\ -1 \end{pmatrix} \text{ \& } \vec{PD} = \begin{pmatrix} -4 \\ 1 \end{pmatrix}$$

$$\text{so } \vec{OA} = \vec{OP} + \vec{PA} = \begin{pmatrix} 1 \\ -1 \end{pmatrix} + \begin{pmatrix} 4 \\ -1 \end{pmatrix} = \begin{pmatrix} 5 \\ -2 \end{pmatrix}$$

$$\& \vec{OB} = \vec{OQ} + \vec{QB} = \begin{pmatrix} 2 \\ 3 \end{pmatrix} + \begin{pmatrix} 4 \\ -1 \end{pmatrix} = \begin{pmatrix} 6 \\ 2 \end{pmatrix}$$

\therefore $5 - 2i, 6 + 2i$ are possible vertices.

By the same argument, (show working of course!)

$-3 + 0i, -2 + 4i$ are also possible vertices

23 Two loci, C_1 and C_2 , are defined by

$$C_1 = \{z: |z| = |z - 4d^2 - 36|\}$$

$$C_2 = \left\{z: \arg(z - 12d - 3i) = \frac{1}{4}\pi\right\}$$

where d is a real number.

(a) Find, in terms of d , the complex number which is represented on an Argand diagram by the point of intersection of C_1 and C_2 .

[You may assume that $C_1 \cap C_2 \neq \emptyset$.] [6]

(b) Explain why the solution found in part (a) is not valid when $d = 3$. [2]

a) C_1 . Method 1: Algebra

$$|x + yi| = |x + yi - 4d^2 - 36|$$

$$\Rightarrow \sqrt{x^2 + y^2} = \sqrt{(x - 4d^2 - 36)^2 + y^2}$$

$$x^2 + y^2 = x^2 + 16d^4 + 36^2 - 8d^2x - 72x + 288d^2 + y^2$$

$$x(72 + 8d^2) = 16d^4 + 288d^2 + 36^2$$

$$x = \frac{16d^4 + 288d^2 + 36^2}{72 + 8d^2} \times \frac{\frac{1}{2}}{\frac{1}{8}}$$

$$= \frac{2d^4 + 36d^2 + 162}{d^2 + 9}$$

$$= \frac{2(d^4 + 18d^2 + 81)}{d^2 + 9}$$

$$= \frac{2(d^2 + 9)^2}{d^2 + 9} = 2d^2 + 18$$

i.e. $x = 2d^2 + 18$

Method 2: Coordinate Geometry (much easier)

$$A = (0, 0) \quad B = (4d^2 + 36, 0)$$

$$M = (2d^2 + 18, 0)$$

$$m_{AB} = \frac{0 - 0}{4d^2 + 36 - 0} = 0$$

\therefore bisector is vertical. $\Rightarrow x = 2d^2 + 18$.

C_2 : half line

starting point $(12d, 3)$

$$\text{gradient} = \tan\left(\frac{1}{4}\pi\right) = 1$$

$$y = x + c$$

$$3 = 12d + c$$

$$c = 3 - 12d$$

$$y = x + 3 - 12d, \quad \underline{\underline{x > 12d}}$$

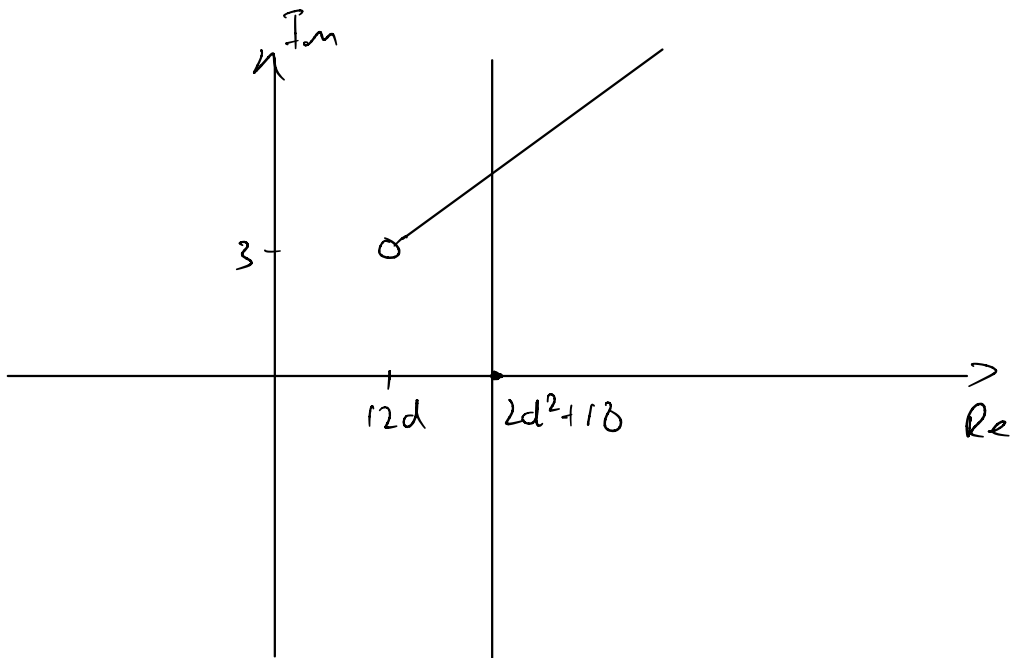

$$C_1 \cap C_2: \quad y = 2d^2 + 18 + 3 - 12d$$

by subbing in
 $x = 2d^2 + 18$

$$= 2d^2 - 12d + 21$$

$$C_1 \cap C_2 = (2d^2 + 18) + (2d^2 - 12d + 21)i$$

b) $d=3$:

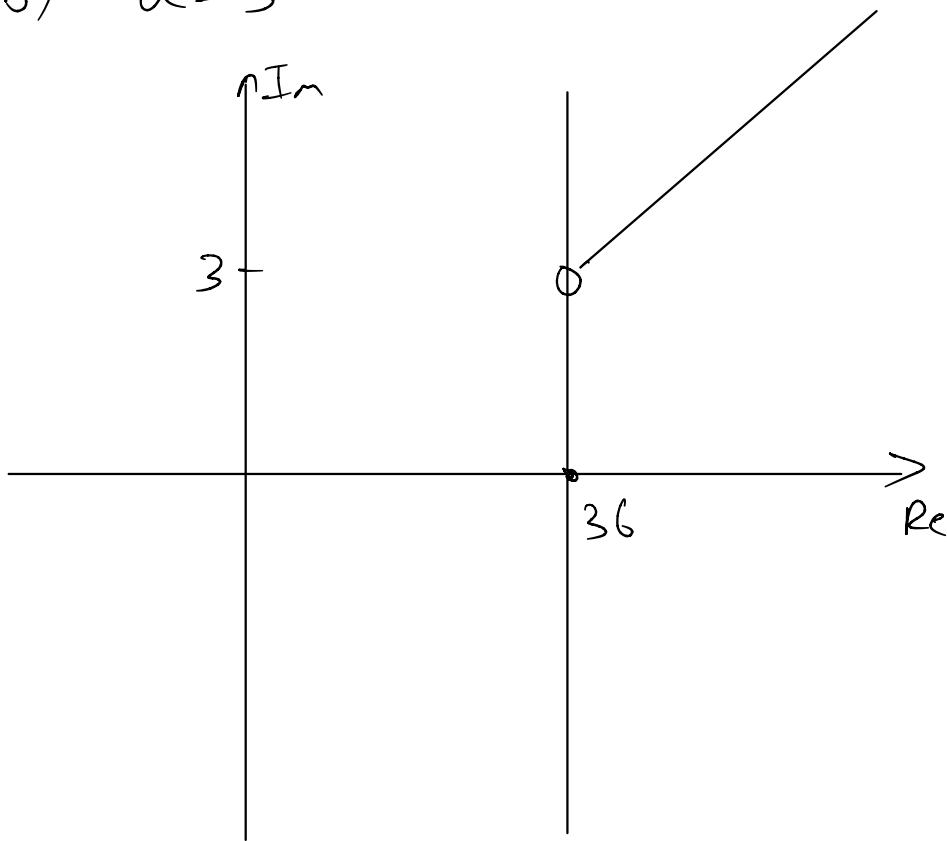

When $d=3$, the point of intersection would be $36+3i$
but $36+3i$ isn't in C_2 since $\arg(o)$ is undefined